



# PROPANE FORGING FURNACE

## H2



If you're looking for a clean, safe flame which makes you turn steel into its red hot point so you can shape it, the Propane Furnace Nargesa is the one. It will be for sure your best choice!



Horseshoes

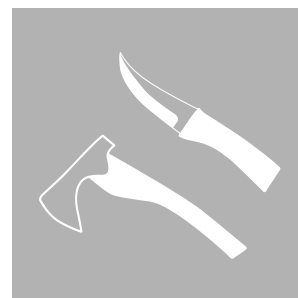

Forging decoration



Knives  
Swords  
Axes

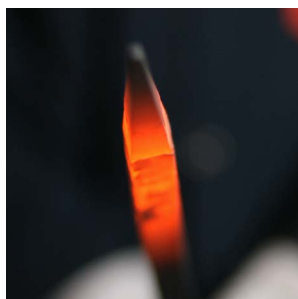

All sort of designs for artistic forging



Iron garden furniture

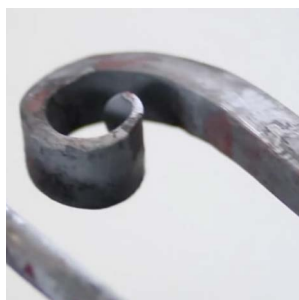

Sculptures in iron



Wrought iron chairs and tables



It is a good substitute for the old Forge, much cleaner, faster and more efficient



H1  
**1** BURNER

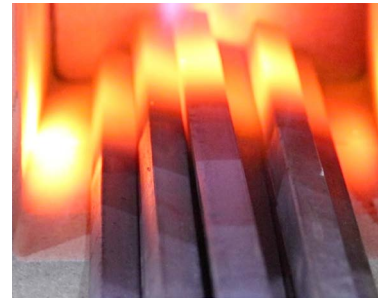

H2  
**2** BURNERS



H3  
**3** BURNERS

# PROPANE FORGING FURNACES

NEW Propane forging furnaces Nargesa are equipped with one, two or three burners to heat the iron and work it: moulding, bending, piercing, welding, tempering, forging, shoeing horses...



## SAFER

It has got new security systems for the operator. Fulfilling the regulation RD919/2006. Certified by the Technological Center APPLUS, General Laboratory for Testing and Investigation.



## MORE EFFICIENT

Consume up to 75% less gas and reach a higher temperature than any oven in its category. More than 1300°C.



## RESPECTFUL WITH THE ENVIRONMENT

Emissions below 0.002% of CO. Internal vermiculite coating, 100% natural and recyclable.



## SAFETY OF THE OPERATOR

The safety of the operator is one of the main premises when designing all Nargesa machines. The H2 forging furnace has got all the necessary safety devices for the well-being of the operator that will handle it and it is according to the Regulation of appliances that use gas as fuel RD919 / 2006.

### **Automatic electronic ignition**

Prevents the operator from inserting his hands in the combustion chamber to turn on the gas. No tool is necessary to generate the spark.

### **Gas system integrated in the oven structure**

The components were totally protected from impacts that could damage and cause leaks.

### **Insulation of the combustion chamber**

These elements are formed by a 100% natural material, compacted vermiculite, not harmful to health. 100% recyclable as it does not include glass fibers or ceramics.

### **Thermocouple safety valve**

This device closes the passage of the gas when the combustion chamber cools due to an anomaly, avoiding any possible leak.

### **Anti-return valve**

This valve regulates the direction of the gas flow preventing it from being addressed to the cylinder.



## ENERGY EFFICIENCY

Saving energy is another topic that our R & D department takes into account for the furnace.

### **Fuel consumption**

The consumption of Nargesa furnaces has been reduced in a 75%, that is to say, it consumes 1/4 of the fuel used by the same furnaces in its category. With a LPG propane gas cylinder of 35Kg, the H2 Furnace will operate 50 hours with its two burners at full operation. If we only use one burner, then performance will duplicate.

### **Gas losses**

There is no fuel, all the propane gas that enters the combustion chamber burns, without any sort of waste. This process has been possible due to the new burners, which have been designed and manufactured by Nargesa.



## RESPECT FOR THE ENVIRONMENT

It is totally infeasible to manufacture machinery and not to take into consideration the planet we inhabit.

### **New generation insulating material**

The insulating material of the combustion chamber, the compacted vermiculite, is a 100% recyclable material and does not generate waste, increasing the heating (thermic) power of the cavity, over 1300°C.

### **CO Emissions**

The emissions emitted by the furnace are 0.002%. In normal environment this value is between 0 and 2. Certified by the General Laboratory of Tests and Investigations: APPLUS Technology Center.



# TECHNICAL FEATURES

## All burners can operate independently

A vermiculite separator is supplied with the Oven to reduce the size of the combustion chamber and thus the heat is not dispersed.

## Insulation of vermiculite

Double insulation of compacted vermiculite, to avoid heat loss. Insulating flange in the material inlets to keep the heat inside the combustion chamber.

## Painting

The furnace is covered with heat painting to protect.

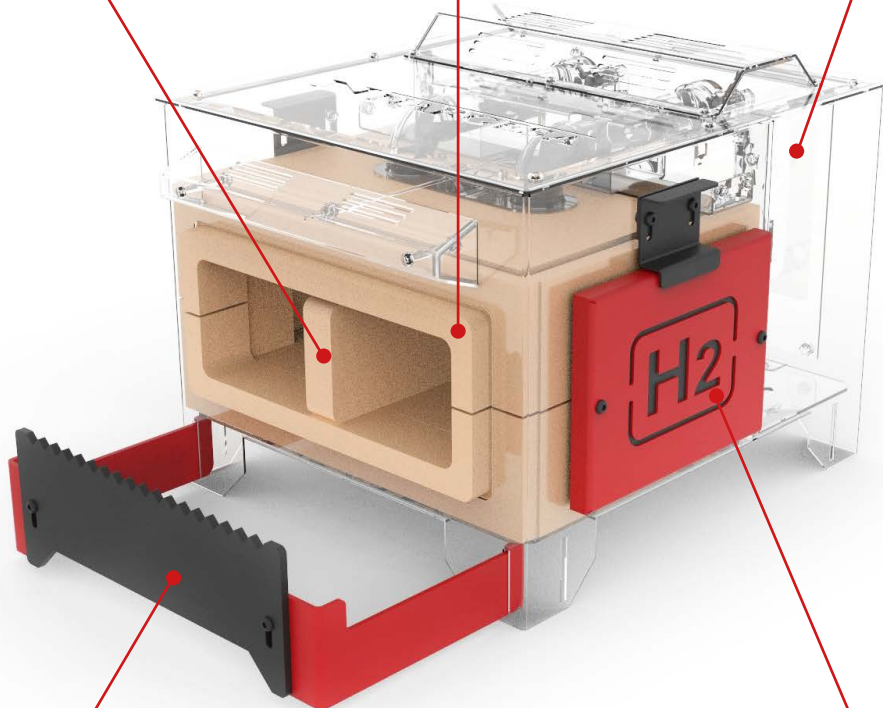

## Integrated bar support and adjustable to the different lengths of material

Its shape prevents the material from sliding laterally. Possibility to place the material support in any of the three entries.

## Removable side doors

To work in the center of the iron bars. The doors are installed without using tools.

All components are standard and easy to find in any warehouse or hardware store

### **Air flow regulator**

To adjust this size to the different altitudes. Depending on the work place of the furnace and its altitude regarding the sea, the air flow for the mixture of gas and marine air will be regulated, the suitability for a good combustion.

### **Needle flow regulation valves**

Allow the accurate regulation of gas flow.

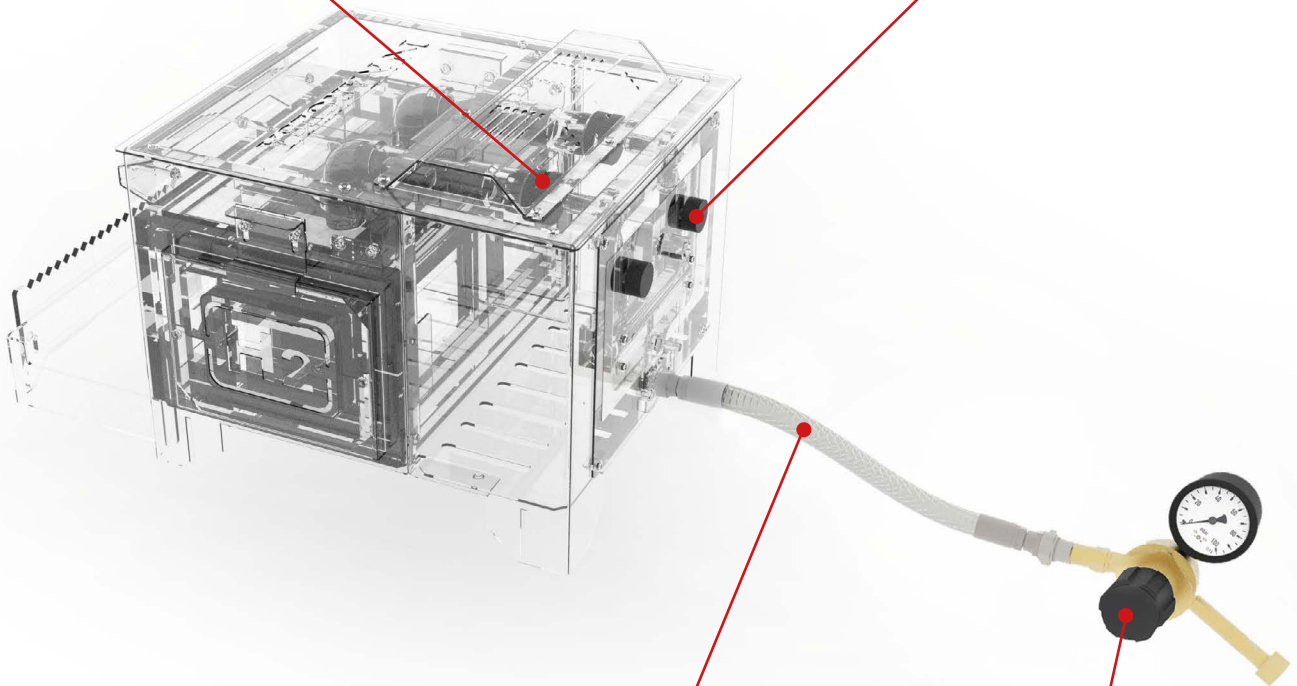

### **Gas hose made of stainless steel**

This characteristic prevent it from collapsing and burning. This hose does not expire, so it is not necessary to replace it.

### **Precision pressure regulator with built-in pressure gauge**

Allows to adjust the gas pressure more precisely.

To regulate the performance of Furnace H2 we have a control panel that enables us to keep the whole operation of the machine in a simple and intuitive way

### Gas valve

The Control panel has got two valves for the opening of the gas entrance to the Burners. The operator controls them in order to obtain more or less gas flow.

### Electronic switching

Is the one that activates the spark plug and generates the spark to light up the Burner.



### Thermocouple pushbutton

Is the one that opens the valve to get the thermocouple activated. This valve opens the path to the Gas valves



# DETAILED FEATURES



## H1

Fuel type	Propane gas (GLP) Ad-
justable working pressure	0.1 - 1.5 bar
External dimensions	310x450x370 mm
Size of combustion chamber	140x236x100 mm
Weight	27 Kg



## H2

Fuel type	Propane gas (GLP) Ad-
justable working pressure	0.1 - 1.5 bar
External dimensions	500x440x370 mm
Size of combustion chamber	324x240x100 mm
Weight	40 Kg



## H3

Fuel type	Propane gas (GLP) Ad-
justable working pressure	0.1 - 1.5 bar
External dimensions	510x580x370 mm
Size of combustion chamber	464x240x100 mm
Weight	53 Kg

Maximum temperature



Number of burners



Power (Hi)



Gas intake as 1 per bar x 1 burner  
x 2 burners  
x 3 burners



## EXTERNAL DIMENSIONS

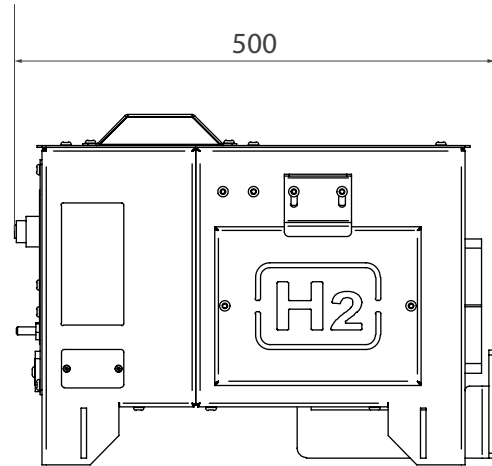
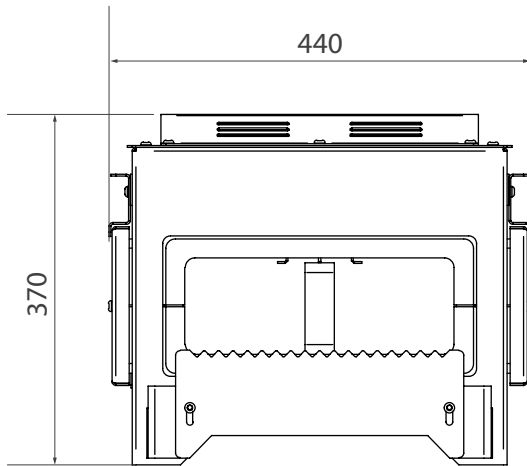

## CHARACTERISTICS OF THE PACKAGING

- Tariff Item Code: 84171000
- Gas furnace is delivered completely mounted.
- Complete wooden packaging NIMF15.

**H2**

Width	800 mm
Length	600 mm
Height	600 mm
Volume	0,288 m <sup>3</sup>
Nett weight	40 Kg
Gross weight	50 Kg